

R.T.A. for CNC Router Machines

A COMPLETE MOTION SOLUTION



Look Ahead!

MOST COMMON CNC MACHINES PROCESSES:

Milling, Turning, Drilling, Grinding,
Cutting, Laser Cutting, Lathing, Carving,
Prototyping and 3D modeling...

APPLICATION FIELDS: Car Components, Home Appliance, Furniture, Medical & Monitor, Electronic Products, Aerospace and Military, Commodities

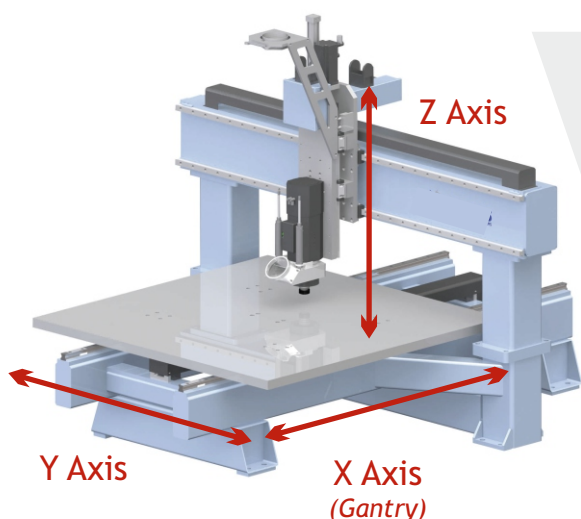

TYPICAL CNC ROUTER MACHINE LAYOUT

Several axes of movement, either linear or rotary.
Many machines have both types.

Further movements (rotation, inclination,
translation...) require further axes.

ACCESSORIES: switching power supplies,
gearboxes, conveyor and pulley, holding brake
on Z axes...

THE ADVANTAGES OF A STEPPER MOTION SOLUTION

- Zero following error
- Immediate gantry (even dynamically)
- Quick setup and easy to use
- Minimum maintenance
- Suitable for harsh environments
- Open-loop or closed-loop options

- **SMOOTHNESS**
- **PRECISION**
- **FLEXIBILITY**
- **INTEGRATION**
- **SAFETY**

R.T.A. ADDED VALUE:

**Integrated
solution:
from software
to accessories**

**40+ Years
Experience**

**Quick
setup
Tuneless
system**

**Motor sizing
Consulting
Service**

**Pre- and
post-sale
technical
assistance**



R.T.A. srl
Via Mattei - Fr. az. Divisa
27020 Marcignago (PV) - ITALY
Tel: +39.0382.929855
Fax: +39.0382.929150
www.rta.it - info@rta.it

R.T.A. Deutschland GmbH
Bublitzer Str. 11
40599 Duesseldorf (Germany)
Tel: +49.211.749.668.60
Fax: +49.211.749.668.66
www.rta-deutschland.de



R.T.A. Iberica S.L.
C/Generalitat 22, Local 1
08850 GA VA - BARCELONA (Spain)
Tel: +34.936.388.805
Fax: +34.936.334.595
www.rta-iberica.es

R.T.A. India Pvt
Teerth Business Center, 3rd Floor, Unit n. 7, Block EL
15, MIDC Bhosari
Pimpri-Chinchwad, Pune 411026 (India)
Tel: +91.9422507445
www.rta-india.in



CNC-KIT 01

230 VAC Solution

PRODUCT	QTY	FEATURES
 X-PLUS L2 Stepping Motor Drive	3	110-230 VAC from the main
 SM2861-5055 Stepping Motor	3	Flange: mm 85.5 Torque: 3.6 Nm
 FRONT BRAKE FB-M12-34-35-00000	1	Voltage: 24 VDC Torque: 3.5 Nm <i>Auxiliary 24 VDC needed</i>

Nema 34
Solution

HIGH
SPEED

TYPICAL RANGE VALUES:*

- 100 µm max dynamical error
- 400 mm/sec
- Up to 50 Kg load



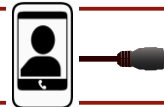

**Based on a 10 mm ball screw pitch example*

1 m cable for front brake included
30 min technical support video-conference included



CNC-KIT 02

48VDC Solution

PRODUCT	QTY	FEATURES
 A-CSD 92 Stepping Motor Drive	3	24-48 VDC
 RH1S3M Stepping Motor	2	Flange: mm 42 Torque: 0.8 Nm JST connector
 RH1S2M.B Stepping Motor with brake	1	Flange: mm 42 Torque: 0.56 Nm JST connector
 R-UHP 350-48 Switching Power Supply	1	48 VDC Current: 7.3 A Power: 350 W

Nema 17
Solution

HIGH
PRECISION

TYPICAL RANGE VALUES:*

- 50 µm max dynamical error
- 100 mm/sec
- Up to 10 Kg load

**Based on a 5 mm ball screw pitch example*

2 m cables kit included
30 min technical support video-conference included

