

HGD Series Drives



INTRODUCTION

- Series of ministep bipolar chopper drives, suitable for driving medium power two-phase stepping motors, with four, six or eight terminals.
- Highly compact (70×70×25 mm), easy to use and cost effective solution. This system is designed to be soldered to a PCB.
- Target: medium and medium-low power applications requiring increase in performance compared to self-built or integrated circuits combined with an improvement of reliability and durability.

HIGHLIGHTS

- Microstepping function up to 3.200 step/rev.
- Separated solder type connectors for logic signals and power connections.
- Electronic damping facility for further acoustic noise and mechanic vibrations reduction at low and medium speed.
- Standard input and output signals ease interfacing with the most commonly used control systems and ensure high noise immunity.

Series	Model	V _{DC} range (Volt)	I _{NP} min. (Peak value) (Amp)	I _{NP} max. (Peak value) (Amp)	Dimensions (mm)
HGD	02	24 to 75	0.75	2.0	70x70x25
HGD	05	24 to 75	2.25	6.0	70x70x25

TECHNICAL FEATURES

- Range of operating voltages: 24-75 V_{DC}.
Operation with a single external supply voltage.
- Range of current: 0.75-6.0 Amp. Setting up to six possible values by means of hardware connections.
- Microstepping: 400, 800, 1.600 and 3.200 steps /revolution. Setting by means of hardware connections.
- Automatic current reduction at motor standstill.
- Protections:
 - Protection against under-voltage and over-voltage.
 - Protection against a short-circuit at motor outputs.
 - Overtemperature protection.
- Possibility to reduce motor current with an external logic signal.
- High efficiency CHOPPER with MOSFET final stage output.
- Electronic damping facility for further acoustic noise and mechanic vibrations reduction at low and medium speed.
- Warranty: 24 months.



MECHANICAL DIMENSIONS

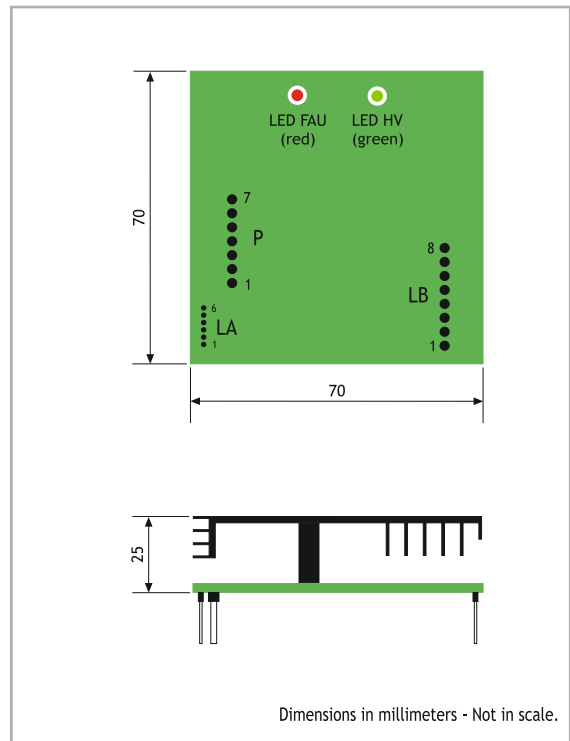

POWER AND LOGIC CONNECTIONS

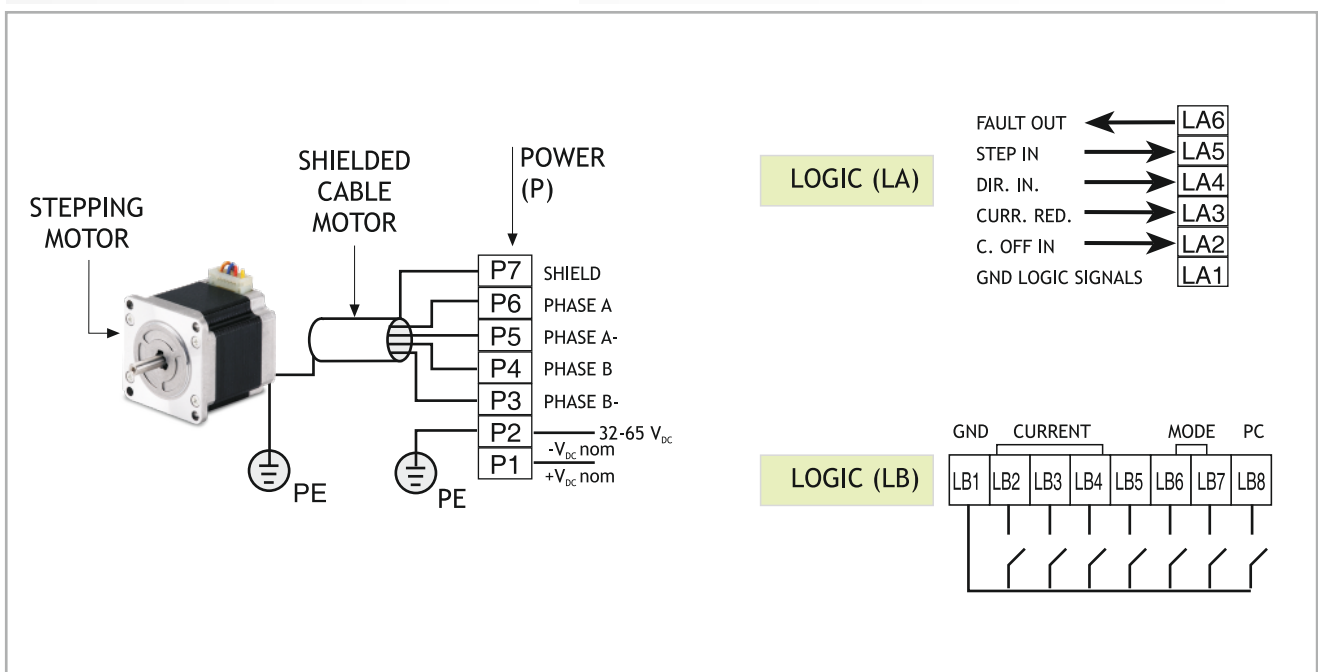

R.T.A. s.r.l.
Via E. Mattei - Frazz. Divisa
27020 Marcignago (PV) (Italy)
T +39.0382.929.855
F +39.0382.929.150
www.rta.it

R.T.A. Deutschland GmbH
Bublitz Strasse 34, 40599
Duesseldorf (Germany)
T +49.211.749.668.60
F +49.211.749.668.66
www.rta-deutschland.de

R.T.A. IBERICA
C/Generalitat 22, Local 1
08850 Gava - Barcelona (Spain)
T +34 936.388.805
F +34 936.334.595
www.rta-iberica.es

R.T.A. INDIA Pvt
Teerth Business Center 3rd Floor, Unit No. 7,
Block EL-15, MIDC Bhosari Pimpri-Chinchwad,
Pune 411026 (India)
Tel. +91 9422507445
www.rta-india.in