

EM 3F3H-OXXO

Dimensions (Unit:mm)

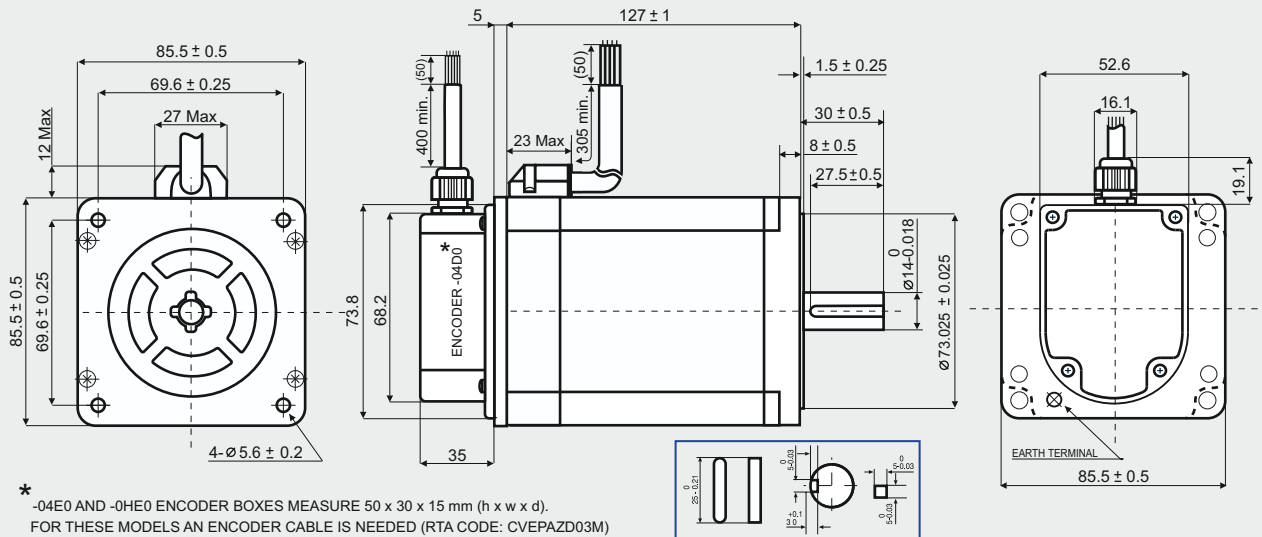

* -04E0 AND -0HE0 ENCODER BOXES MEASURE 50 x 30 x 15 mm (h x w x d).
FOR THESE MODELS AN ENCODER CABLE IS NEEDED (RTA CODE: CVEPAZD03M)

SANYO DENKI MOTOR FEATURES

MODEL	EM 3F3H-OXXO
SANYO DENKI MOTOR CODE	SM 2863-5225
BASIC STEP ANGLE	1.8° ± 0.09°
BIPOLAR PARALLEL CURRENT	(Amp) 6.0
RESISTANCE	(Ohm) 0.46
INDUCTANCE	(mH) 3.8
BIPOLAR HOLDING TORQUE	(Ncm) 920
ROTOR INERTIA	(Kg·m ² × 10 ⁻⁷) 4500
THEORETICAL ACCELERATION	(rad × sec. ⁻²) 20500
BACK E.M.F.	(V/Krpm) 161
MASS	(Kg) 4.0
INTERNATIONAL STANDARDS	UL, CSA
INSULATION VOLTAGE	(V) 250 VAC (350 VDC)
PROTECTION DEGREE - INSULATION CLASS	IP43 - F
LEADS CODE	V

TORQUE/SPEED CURVE

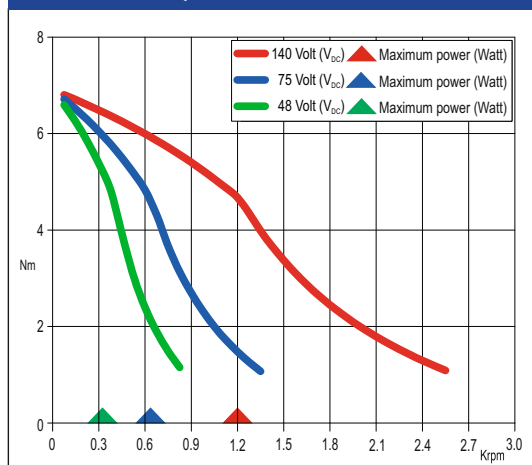

R.T.A. s.r.l. PAVIA (ITALY) SANYO DENKI CO., Ltd (JAPAN)

ENCODER OPTIONS:	EM 3F3H-04D0	EM 3F3H-04E0 *	EM 3F3H-0HE0 *
RESOLUTION	400 cpr	400 cpr	4000 cpr
INDEX	No	Yes	Yes
CURRENT CONSUMPTION (mA)	50	50	85
HIGH LEVEL OUTPUT (Volt)	5 (TIP) - 4.75 (MIN) (I _{MAX} =25mA)	3.4 (TIP) - 2.4 (MIN) (I _{MAX} =20mA)	3.4 (TIP) - 2.4 (MIN) (I _{MAX} =20mA)
LOW LEVEL OUTPUT (Volt)	0.25 (TIP) - 0.6 (MAX) (I _{MAX} =25mA)	0.2 (TIP) - 0.4 (MAX) (I _{MAX} =20mA)	0.2 (TIP) - 0.4 (MAX) (I _{MAX} =20mA)
OUTPUT SIGNAL	Differential	Differential	Differential
MAXIMUM FREQUENCY (KHz)	100	100	720
POWER SUPPLY VOLTAGE (Volt)	5 V _{DC} ± 10%	5 V _{DC} ± 10%	5 V _{DC} ± 10%

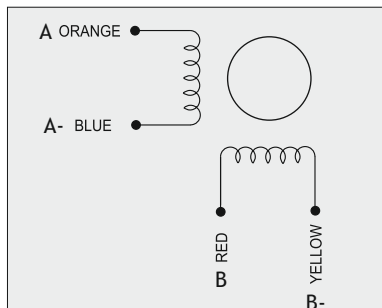

DESCRIPTION	04D0	04E0 PINS	0HE0 PINS
CHANNEL A+	● BLUE	6 ● GREEN	6 ● GREEN
CHANNEL A-	● BROWN	5 ● PURPLE	5 ● PURPLE
CHANNEL B+	● GREEN	8 ● BLUE	8 ● BLUE
CHANNEL B-	● PURPLE	7 ● BROWN	7 ● BROWN
+ DC (5V)	● RED	2 ● RED	2 ● RED
GROUND	● BLACK	3 ● BLACK	3 ● BLACK
INDEX+	/	10 ● ORANGE	10 ● ORANGE
INDEX-	/	9 ○ WHITE	9 ○ WHITE

R.T.A. CABLE

CVEPAZD03M

CVEPAZD03M

Suggested R.T.A. drive series: NDC, ADW, HGD, PLUS



R.T.A. s.r.l.
Via E. Mattei - Fraz- Divisa
27020 Marcignago (PV) (Italy)
T +39.0382.929.855
F +39.0382.929.150
www.rta.it

R.T.A. Deutschland GmbH
Bublitzer Strasse 34, 40599
Duesseldorf (Germany)
T +49.211.749.668.60
F +49.211.749.668.66
www.rta-deutschland.de

R.T.A. IBERICA
C/Generalitat 22, Local 1
08850 Gava - Barcelona (Spain)
T +34 936.388.805
F +34 936.334.595
www.rta-iberica.es

R.T.A. INDIA Pvt
Teerth Business Center 3rd Floor, Unit No. 7,
Block EL-15, MIDC Bhosari Pimpri-Chinchwad,
Pune 411026 (India)
Tel. +91 9422507445
www.rta-india.in