

103-H7126-0740

SANYO DENKI
SANMOTION

Dimensions (Unit:mm)

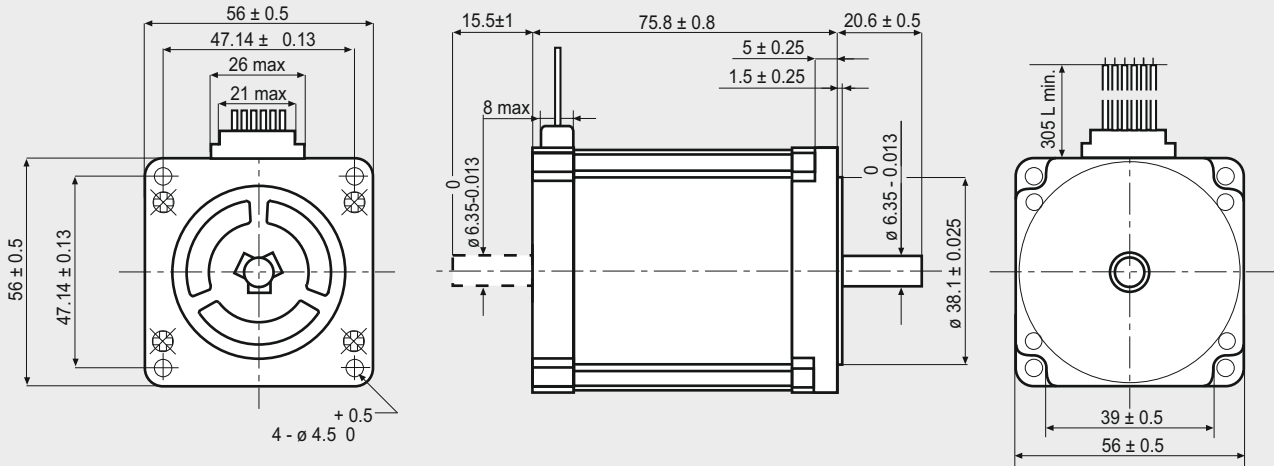

FEATURES

MODEL	103-H7126-0740 (103-H7126-0710)	
BASIC STEP ANGLE	1.8° ± 0.09°	
BIPOLAR CURRENT	(Amp)	2.2 ^(*)
UNIPOLAR CURRENT	(Amp)	3
RESISTANCE	(Ohm)	0.9
INDUCTANCE	(mH)	2.2
BIPOLAR HOLDING TORQUE	(Ncm)	165
UNIPOLAR HOLDING TORQUE	(Ncm)	130
ROTOR INERTIA	(Kg m ² x 10 ⁻⁷)	360
THEORETICAL ACCELERATION	(rad x sec. ⁻²)	45800
BACK E.M.F.	(V/Krpm)	31
MASS	(Kg)	1
LEADS CODE	IV	

Codes between brackets refer to double shaft models.

TORQUE/SPEED CURVE

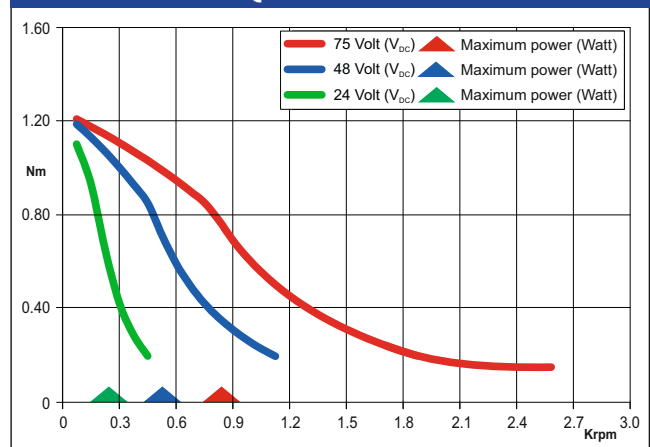

(*)Bipolar series connection.

R.T.A. s.r.l. PAVIA (ITALY) SANYO DENKI CO., Ltd (JAPAN)

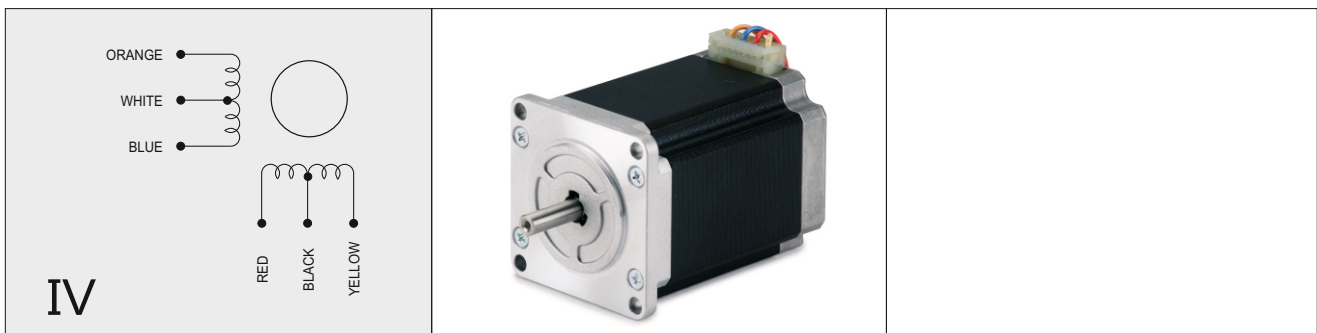

Suggested R.T.A. drive series: BSD, CSD, NDC, ADW, HGD, FLEX-DRIVE



R.T.A. s.r.l.
Via E. Mattei - Fraz- Divisa
27020 Marcignago (PV) (Italy)
T +39.0382.929.855
F +39.0382.929.150
www.rta.it

R.T.A. Deutschland GmbH
Bublitzer Strasse 34, 40599
Duesseldorf (Germany)
T +49.211.749.668.60
F +49.211.749.668.66
www.rta-deutschland.de

R.T.A. IBERICA
C/Generalitat 22, Local 1
08850 Gava - Barcelona (Spain)
T +34 936.388.805
F +34 936.334.595
www.rta-iberica.es

R.T.A. INDIA Pvt
Teerth Business Center 3rd Floor, Unit No. 7,
Block EL-15, MIDC Bhosari Pimpri-Chinchwad,
Pune 411026 (India)
Tel. +91 9422507445
www.rta-india.in