

103-H6701-0140

SANYO DENKI
SANMOTION

Dimensions (Unit:mm)

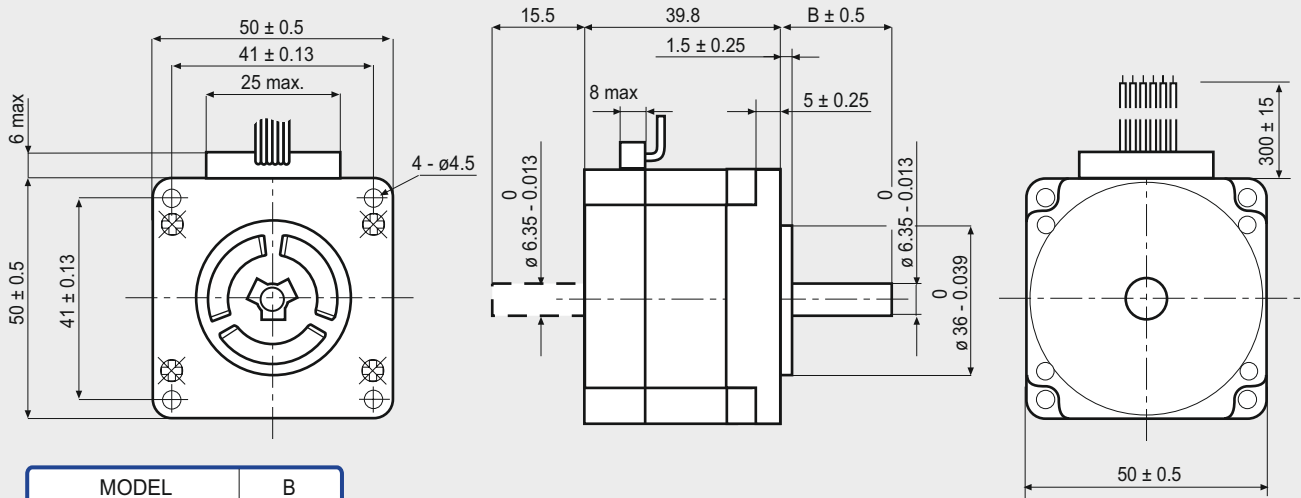

MODEL	B
103 - H6701 - 0140	20.6
103 - H6701 - 0113	28

FEATURES

MODEL	103-H6701-0140 (103-H6701-0113)
BASIC STEP ANGLE	1.8° ± 0.09°
BIPOLAR CURRENT (Amp)	0.7 ^(*)
UNIPOLAR CURRENT (Amp)	1.0
RESISTANCE (Ohm)	4.3
INDUCTANCE (mH)	6.8
BIPOLAR HOLDING TORQUE (Ncm)	38
UNIPOLAR HOLDING TORQUE (Ncm)	28
ROTOR INERTIA (Kg·m ² × 10 ⁻⁷)	57
THEORETICAL ACCELERATION (rad × sec. ⁻²)	66000
BACK E.M.F. (V/Krpm)	20
MASS (Kg)	0.35
LEADS CODE	IV

Codes between brackets refer to double shaft models.

TORQUE/SPEED CURVE

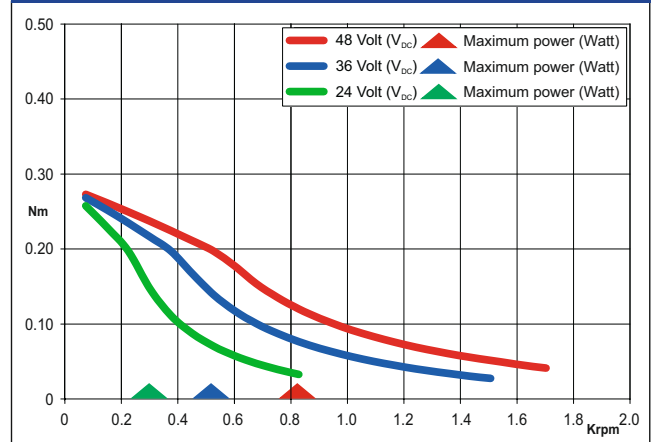

(*)Bipolar series connection.

R.T.A. s.r.l. PAVIA (ITALY) SANYO DENKI CO., Ltd (JAPAN)

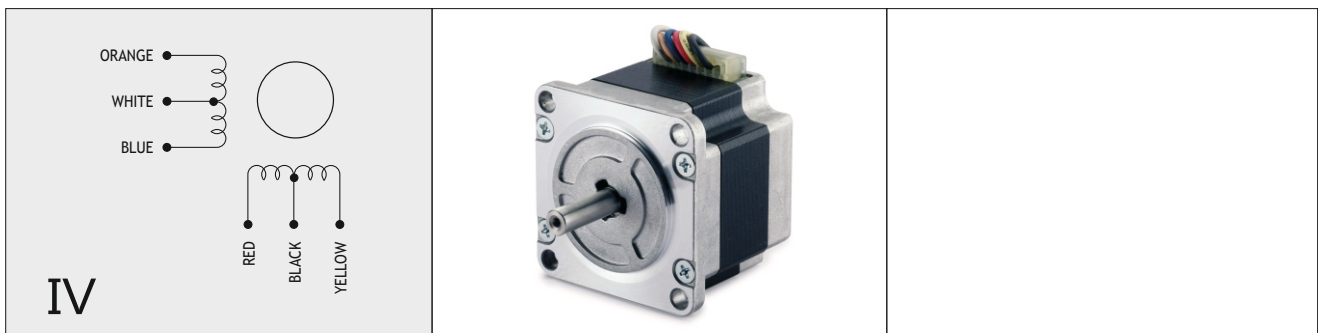

Suggested R.T.A. drive series: BSD, CSD, FLEX-DRIVE



R.T.A. s.r.l.
Via E. Mattei - Fraz- Divisa
27020 Marcignago (PV) (Italy)
T +39.0382.929.855
F +39.0382.929.150
www.rta.it

R.T.A. Deutschland GmbH
Bublitzter Strasse 34, 40599
Duesseldorf (Germany)
T +49.211.749.668.60
F +49.211.749.668.66
www.rta-deutschland.de

R.T.A. IBERICA
C/Generalitat 22, Local 1
08850 Gava - Barcelona (Spain)
T +34 936.388.805
F +34 936.334.595
www.rta-iberica.es

R.T.A. INDIA Pvt
Teerth Business Center 3rd Floor, Unit No. 7,
Block EL-15, MIDC Bhosari Pimpri-Chinchwad,
Pune 411026 (India)
Tel. +91 9422507445
www.rta-india.in