

103-H5212-4640

SANYO DENKI
SANMOTION

Dimensions (Unit:mm)

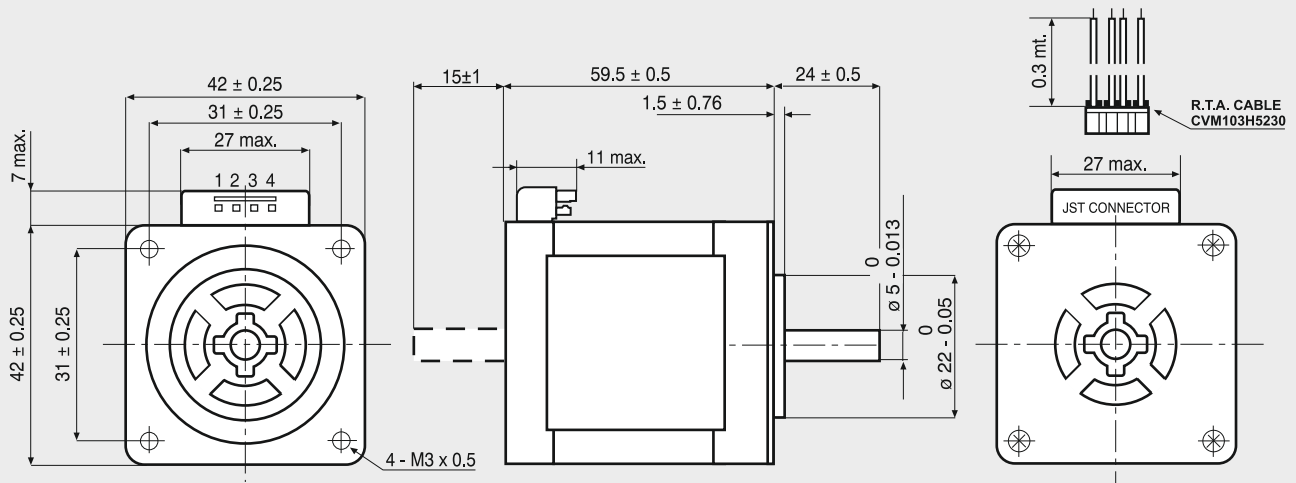

MOTOR CONNECTOR IS JST mod. B6B-EH K 6 POLES MALE.
FOR CONNECTION USE JST mod. EHR-6 FEMALE CONNECTOR AND
mod. SEH-001 T-P0.6 CONTACTS.
NOTE: 103-H5212-4640 MOTORS NEED CVM103H5230 R.T.A. CABLES.
CONTACT R.T.A. FOR FURTHER DETAILS.

FEATURES

MODEL	103-H5212-4640 (103-H5212-4610)
BASIC STEP ANGLE	1.8° ± 0.09°
BIPOLAR CURRENT (Amp)	2.0
UNIPOLAR CURRENT (Amp)	
RESISTANCE (Ohm)	1.5
INDUCTANCE (mH)	3.0
BIPOLAR HOLDING TORQUE (Ncm)	65
UNIPOLAR HOLDING TORQUE (Ncm)	
ROTOR INERTIA (Kg m ² x 10 ⁻⁷)	110
THEORETICAL ACCELERATION (rad x sec. ⁻²)	59000
BACK E.M.F. (V/Krpm)	32
MASS (Kg)	0.35
LEADS CODE	V

Codes between brackets refer to double shaft models.

TORQUE/SPEED CURVE

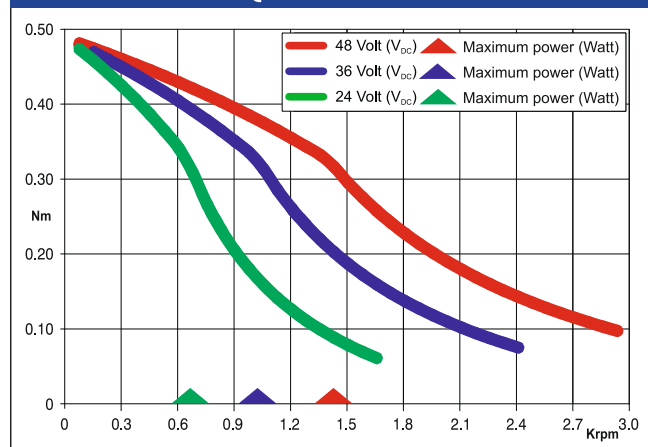

R.T.A. s.r.l. PAVIA (ITALY) SANYO DENKI CO., Ltd (JAPAN)



Suggested R.T.A. drive series: BSD, CSD, FLEX-DRIVE



R.T.A. s.r.l.
Via E. Mattei - Fraz- Divisa
27020 Marcignago (PV) (Italy)
T +39.0382.929.855
F +39.0382.929.150
www.rta.it

R.T.A. Deutschland GmbH
Bublitzter Strasse 34, 40599
Duesseldorf (Germany)
T +49.211.749.668.60
F +49.211.749.668.66
www.rta-deutschland.de

R.T.A. IBERICA
C/Generalitat 22, Local 1
08850 Gava - Barcelona (Spain)
T +34 936.388.805
F +34 936.334.595
www.rta-iberica.es

R.T.A. INDIA Pvt
Teerth Business Center 3rd Floor, Unit No. 7,
Block EL-15, MIDC Bhosari Pimpri-Chinchwad,
Pune 411026 (India)
Tel. +91 9422507445
www.rta-india.in