

SM 2861-5225.B

Dimensions (Unit:mm)

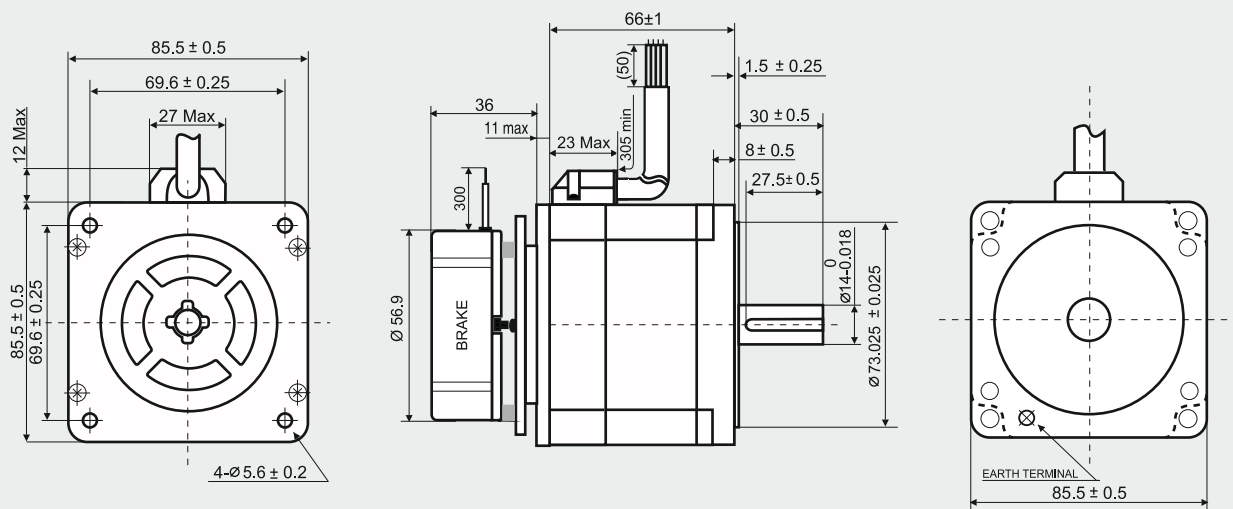

SANYO DENKI MOTOR FEATURES

MODEL	SM 2861-5225.B
SANYO DENKI MOTOR CODE	SM 2861-5225
BASIC STEP ANGLE	$1.8^\circ \pm 0.09^\circ$
BIPOLAR PARALLEL CURRENT (Amp)	6.0
RESISTANCE (Ohm)	0.29
INDUCTANCE (mH)	1.7
BIPOLAR HOLDING TORQUE (Ncm)	360
ROTOR INERTIA ($\text{Kg} \cdot \text{m}^2 \times 10^{-7}$)	1480
THEORETICAL ACCELERATION ($\text{rad} \times \text{sec}^{-2}$)	24300
BACK E.M.F. (V/Krpm)	60
MASS (Kg)	2.2
INTERNATIONAL STANDARDS	UL, CSA
INSULATION VOLTAGE (V)	250 VAC (350 VDC)
PROTECTION DEGREE - INSULATION CLASS	IP43 - F
LEADS CODE	V

TORQUE/SPEED CURVE

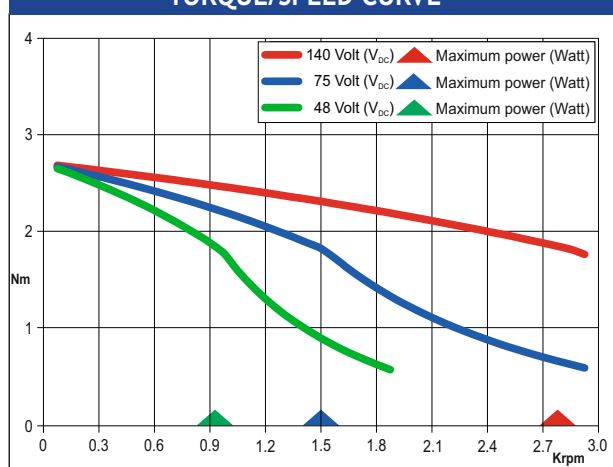

R.T.A. s.r.l. PAVIA (ITALY) SANYO DENKI CO., Ltd (JAPAN)

BRAKE FEATURES

STATIC TORQUE (Nm)	3.3
DUTY CYCLE	50% max.
VOLTAGE (Volt)	24 VDC
POWER (W)	11
RELEASE TIME (ms)	300



Suggested R.T.A. drive series: NDC, ADW, HGD, PLUS



R.T.A. s.r.l.
Via E. Mattei - Fraz- Divisa
27020 Marcignago (PV) (Italy)
T +39.0382.929.855
F +39.0382.929.150
www.rta.it

R.T.A. Deutschland GmbH
Bublitzter Strasse 34, 40599
Duesseldorf (Germany)
T +49.211.749.668.60
F +49.211.749.668.66
www.rta-deutschland.de

R.T.A. IBERICA
C/Generalitat 22, Local 1
08850 Gava - Barcelona (Spain)
T +34 936.388.805
F +34 936.334.595
www.rta-iberica.es

R.T.A. INDIA Pvt
Teerth Business Center 3rd Floor, Unit No. 7,
Block EL-15, MIDC Bhosari Pimpri-Chinchwad,
Pune 411026 (India)
Tel. +91 9422507445
www.rta-india.in