

# ROBOTICS SOLUTIONS

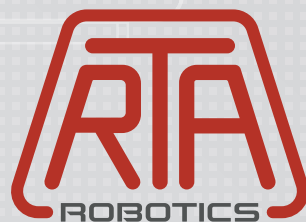



# ROBOTICS SOLUTIONS

## INDEX



INTRODUCING R.T.A. ROBOTICS



ARTICULATED ROBOTS



SCARA ROBOTS

4

11

19

# ● Introducing R.T.A. Robotics



R.T.A. Robotics is an innovative, high-tech start-up, founded by R.T.A. srl in compliance with the Italian law DL 179/2012. It is focused on the robotic and industrial automation market with a dedicated technical team and a comprehensive portfolio of robotics solutions.

The growing technical and commercial synergies between Automation and Robotics, reinforced by R.T.A.'s robust know-how and experience in industrial automation solutions, offer to R.T.A. Robotics' customers important growth opportunities.

As the "core" components of R.T.A. robots belong to R.T.A. mechatronics products portfolio since many years, the articulated and SCARA robotic high-end solutions ground themselves into a robust industrial automation environment.



# ● R.T.A. Robotics & University of Pavia: a strategic high-value partnership



R.T.A. Robotics has signed an important collaboration agreement with the Industrial Engineering Department of the University of Pavia, based on long-lasting mutual trust and cooperation between the two parties.

In the RAMSLAB - Research on Advanced Mechanical System Laboratory, a group of post-doc engineers is offering high-level technical support, working closely in team with R.T.A. Robotics technical staff.

From its side, R.T.A. opens the doors to University, in order to develop joint activities and exchange information and know-how in a continuous collaboration between University and private sector.

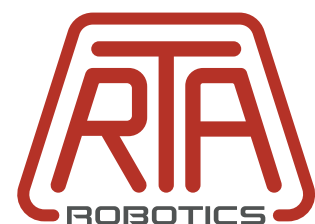

UNIVERSITÀ  
DI PAVIA

# R.T.A. Robotics Solutions



With 7 models, among articulated robots and SCARA robots, R.T.A. Robotics offers a comprehensive range of industrial robotics solutions.

Suiting diverse applications and industries, R.T.A. robots are strongly integrated in R.T.A. motion control hardware and software architectures and offering flexible and easy-to-operate complete solutions.



**R.T.A. ROBOTICS SOLUTIONS ARE POWERED BY R.T.A. 45+ YEARS EXPERIENCE IN MOTION CONTROL**



## Articulated robots main advantages

- Versatility
- Easy to set-up
- Repeatability
- Strength
- Singularity-free mechanics

Typical applications, where strength and flexibility are required:

- Loader/unloader
- Pick and place
- Workpiece testing
- Palletizing
- Stacking
- Packaging



## SCARA robots main advantages

- Speed
- Integration
- Precision
- Connectivity
- Low maintenance

Typical applications, where speed and precision are required:

- Assembling/Disassembling
- Pick and place
- Dispensing
- Sorting
- Product inspections
- End of line

## Product line-up

### Articulated robots

### SCARA robots

MODEL	HORST 600	HORST 900	HORST 1400	RX3-400	RX6-500	RX6-600	RX6-700
							
NUMBER OF AXIS	6	6	6	4	4	4	4
MAX. RANGE	584 mm	905 mm	1425 mm	400 mm	500 mm	600 mm	700 mm
MAX. PAYLOAD	3 kg	5 kg	12 kg	3 kg	6 kg	6 kg	6 kg

## Strong integration with R.T.A. motion solutions

Handshaking between a robot and a complete motion control architecture can be technically challenging and it can require long time to set-up.

R.T.A. offers true robot and machine integration, thanks to its 45+ years experience in hardware solutions and a robust know-how in software engineering.

The result is a scalable coordinated system, which R.T.A. Robotics' team of software and hardware Engineers is very familiar with, for virtually any industrial application.

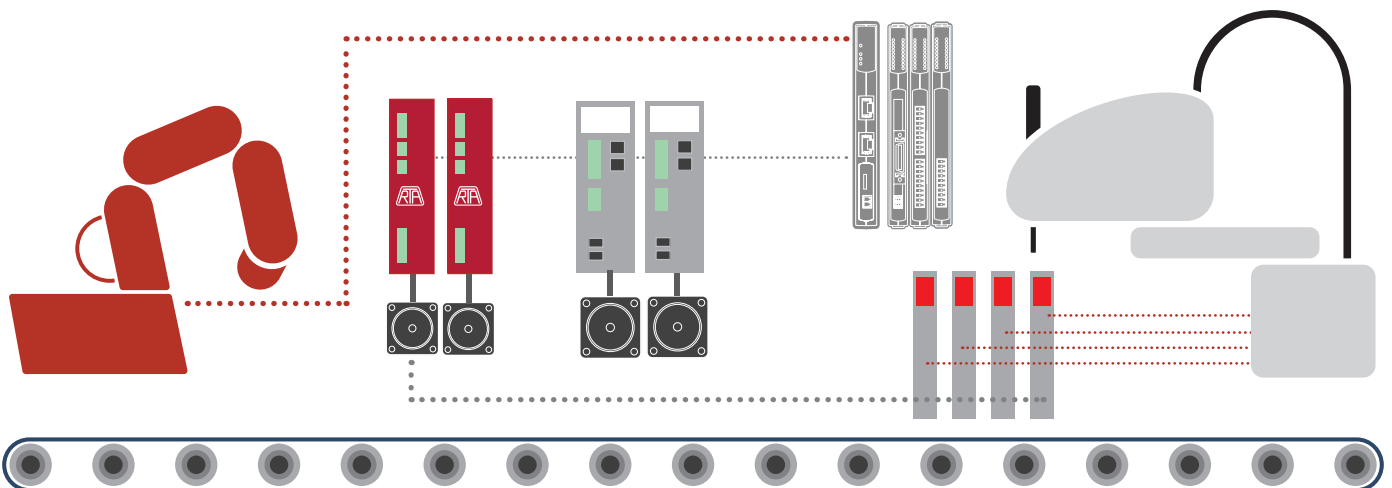



## ● R.T.A. Robotics Associations and Partners



Siri is the Italian Association of Robotics and Automation, which includes research institutions, universities, manufacturers, integrators, importers operating in the robotics and automation sectors among its associates.



Assolombarda is part of Confindustria (Italian Entrepreneurial Association) and it is the largest territorial association of the Italian entrepreneurial system. It gathers nearly 7000 companies, employing more than 420.000 workers in Northern Italy and several hundred thousands in the whole country.



University of Pavia is one of the oldest in the world and today it is a Research University with a leading role and top quality achievements in its 18 teaching Departments, in close association with public and private institutions, enterprises and companies.



ITS Lombardia Meccatronica is a tertiary education institute providing courses in various fields of mechatronics, aimed at graduates who want to further qualify their professional skills with high-level training and on-the-field internships in the associated companies.

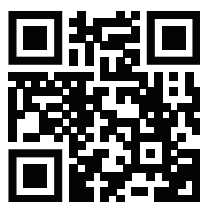

**DOWNLOAD  
THE PRESS-KIT HERE**





## ARTICULATED ROBOTS



# HORST 600 Fast

Horst 600 Fast is a compact and lightweight 6 axis industrial robot, operating at high speed with top precision.

The small space requirements and the extremely high accuracy make it very appealing for short production cycles such as pick and place, handling and assembling of small components and precise positioning in general.

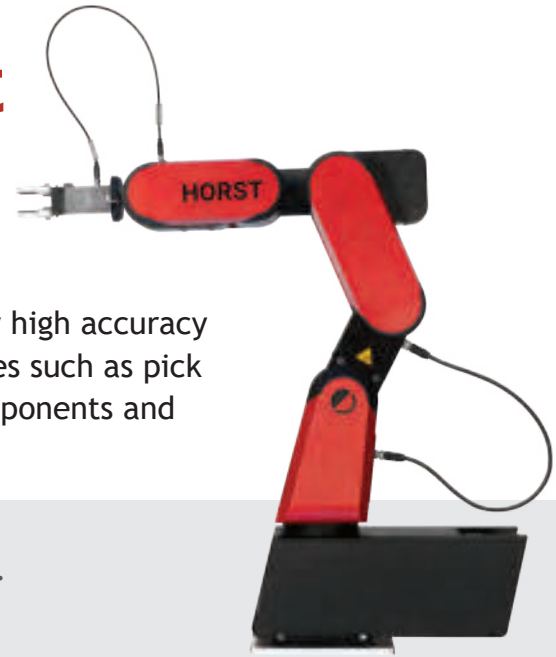

## Highlights

- 584 mm maximum range.
- Up to 3 kg payload.
- +/- 0.05 mm repeatability.

## Main features

Number of axes	6
Maximum payload	3 kg <sup>1</sup>
Nominal load	2 kg
Maximum range	584 mm
Repeatability	+/- 0.05 mm
Protection	IP54
Weight	ca. 29 kg
Installation area	382 x 200 mm
Power supply	230 VAC, 50-60 Hz, 450 W/600 W

## Axis data

Axis	Stroke	Max Speed
1	+/-173°	370°/s
2	- 64°/+115°	140°/s
3	- 176°/+41°	420°/s
4	+/-172°	1220°/s
5	+/-142°	940°/s
6	+/-300°	1280°/s



**ACCESS HERE FURTHER TECHNICAL INFORMATION**

## Operating Range

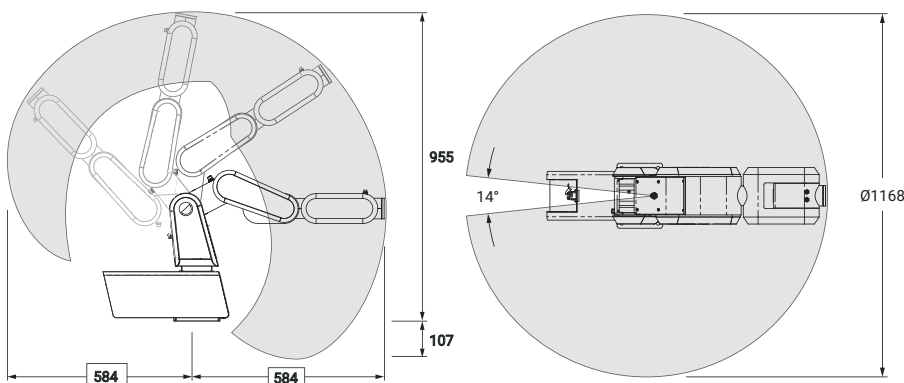

## Drilling pattern

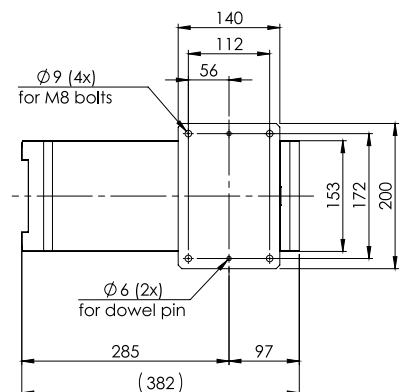

## User Interface

HorstFX allows to easily create industrial robot programs without having to write textual codes.

The intuitive graphic interface has been developed for the included operating panel with touch screen, but it also works on desktop for maximum flexibility.



## Horst 600 Fast includes

- Switch cabinet
- Robot control touch panel
- HorstFX software

## Control and interfaces horstCONTROL

Dimensions (H x B x T)	313 mm x 174 mm x 446 mm
I/O connections on switch cabinet	20 digital input (expandable to 28) 18 digital output (expandable to 30)
I/O connections on tool flange	M8 male, 4-pin, angled, A-coded
I/O power supply	24V/7A at control 24V/2.5A at tool flange
Communication	TCP/IP 100-Mbit/s Ethernet [Web-Interface via HTTP]
Safety-relevant interfaces	Emergency stop [input and output]; Safety stop [input and output] in accordance with DIN EN ISO 10218-1
Fieldbus	Modbus/TCP Optional: Profinet

## Upstream communication possibilities

Modbus TCP/IP via Ethernet port



TCP/IP Sockets via Ethernet port



## Tool connectivity

Each interface provides power and control signals for grippers and sensors.

- 2 digital inputs/outputs
- 24 VDC current

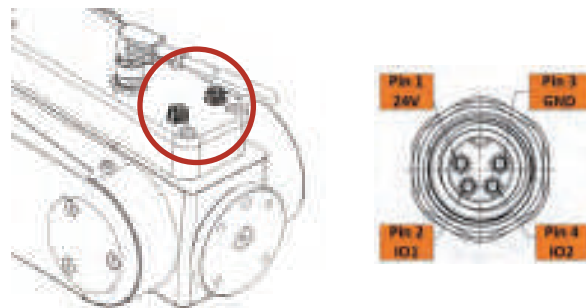

Electric grippers → No pneumatics → Easy maintenance

## Tool mounting Flange

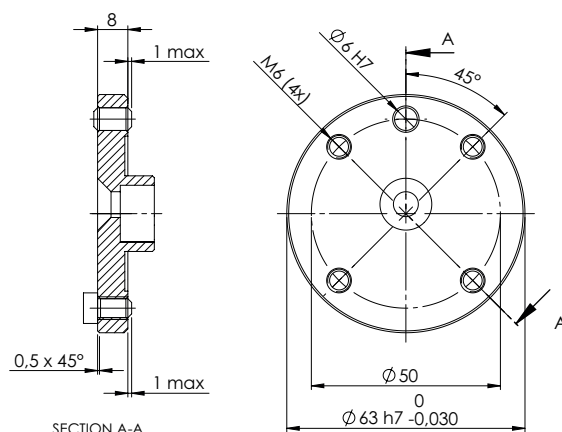

## Mobile robot base (available upon request)

A versatile multi-purpose platform equipped with emergency stop button, mounts for cabinet and panel and lockable door.

The aluminium base has multiple drilling patterns.



# HORST 900

Horst 900 is a 6 axis industrial robot characterized by particularly high working speeds for its size. It offers an optimum ratio of range and payload, quickly handling loads of up to 5 kilograms in a compact working area. Its ideal application fields are fitting, assembling, screwing, palletizing, stacking and packaging.



## Highlights

- 905 mm maximum range.
- Up to 5 kg payload.
- +/- 0.05 mm repeatability.

### Main features

Number of axes	6
Maximum payload	5 kg <sup>1</sup>
Nominal load	3 kg
Maximum range	905 mm
Repeatability	+/- 0.05 mm
Protection	IP54
Weight	ca. 55 kg
Installation area	380 x 380 mm
Power supply	230 VAC, 50-60 Hz, 650 W/800 W

### Axis data

Axis	Stroke	Max Speed
1	±176°	280°/s
2	-16°/+86.5°	150°/s
3	-67°/+ 42°	300°/s
4	±171°	900°/s
5	±119°	750°/s
6	±300°	1150°/s



**ACCESS HERE FURTHER  
TECHNICAL INFORMATION**

### Operating Range

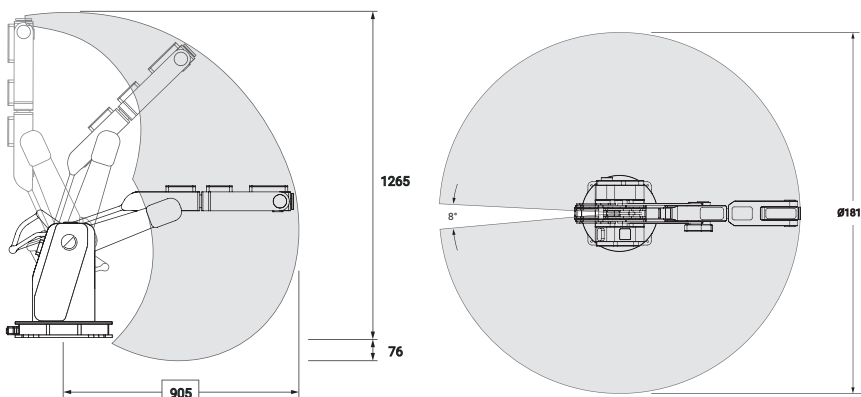

### Drilling pattern

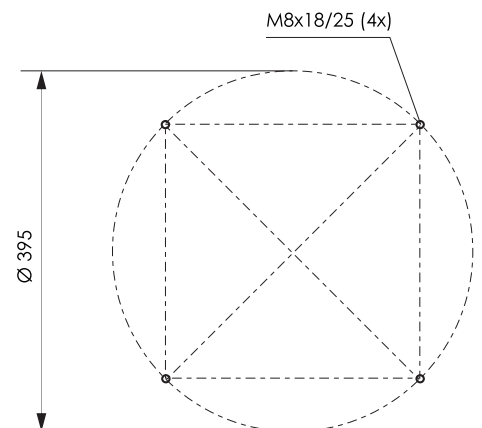

# User Interface

HorstFX allows to easily create industrial robot programs without having to write textual codes.

The included operating panel with touch screen, but it also works on desktop for maximum flexibility.



## Horst 900 includes

- Switch cabine
- Robot control touch panel
- HorstFX software

## Control and interfaces horstCONTROL

Dimensions (H x B x T)	313 mm x 174 mm x 446 mm
I/O connections on switch cabinet	20 digital input (expandable to 28) 18 digital output (expandable to 30)
I/O connections on tool flange	M8 male, 4-pin, angled, A-coded
I/O power supply	24V/7A at control 24V/2.5A at tool flange
Communication	TCP/IP 100-Mbit/s Ethernet [Web-Interface via HTTP]
Safety-relevant interfaces	Emergency stop [input and output]; Safety stop [input and output] in accordance with DIN EN ISO 10218-1
Fieldbus	Modbus/TCP Optional: Profinet

## Upstream communication possibilities

Modbus TCP/IP via Ethernet port



TCP/IP Sockets via Ethernet port



## Mobile robot base (available upon request)

A versatile multi-purpose platform equipped with emergency stop button, mounts for cabinet and panel and lockable door.

The aluminium base has multiple drilling patterns.



## Tool connectivity

Each interface provides power and control signals for grippers and sensors.

- 2 digital inputs/outputs
- 24 VDC current

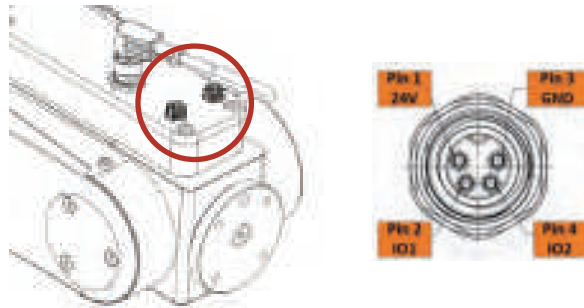

Electric grippers → No pneumatics → Easy maintenance

## Tool mounting Flange

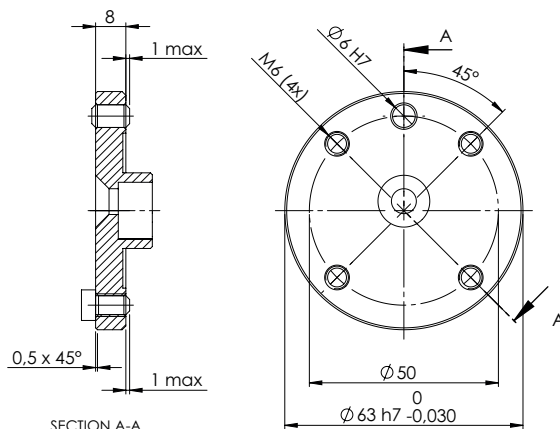

# HORST 1400

HORST 1400 is the ideal robotic solution for a wide variety of industrial automation tasks in logistics, handling plastic, wood or metal parts with an extended operating range. Robust, strong, but highly accurate, HORST 1400 provides high performances in all sectors and applications, handling payloads of up to 12 kg with high repeat accuracy.



## Highlights

- 1425 mm maximum range.
- Up to 12 kg payload.
- $\pm 0.1$  mm repeatability.

## Main features

Number of axes	6
Maximum payload	12 kg <sup>1</sup>
Nominal load	8 kg
Maximum range	1425 mm
Repeatability	$\pm 0.1$ mm
Protection	IP54
Weight	ca. 150 kg
Installation area	474 x 474 mm
Power supply	230 VAC, 50-60 Hz, 850 W/1000 W

## Axis data

Axis	Range of movement	Speed <sup>2</sup>
1	$\pm 177^\circ$	175°/s
2	$-13^\circ/+85^\circ$	50°/s
3	$-59^\circ/+54^\circ$	100°/s
4	$\pm 171^\circ$	850°/s
5	$\pm 117^\circ$	780°/s
6	$\pm 300^\circ$	1050°/s

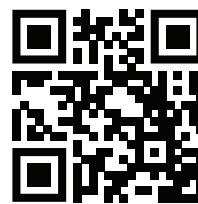

**ACCESS HERE FURTHER TECHNICAL INFORMATION**

## Operating Range

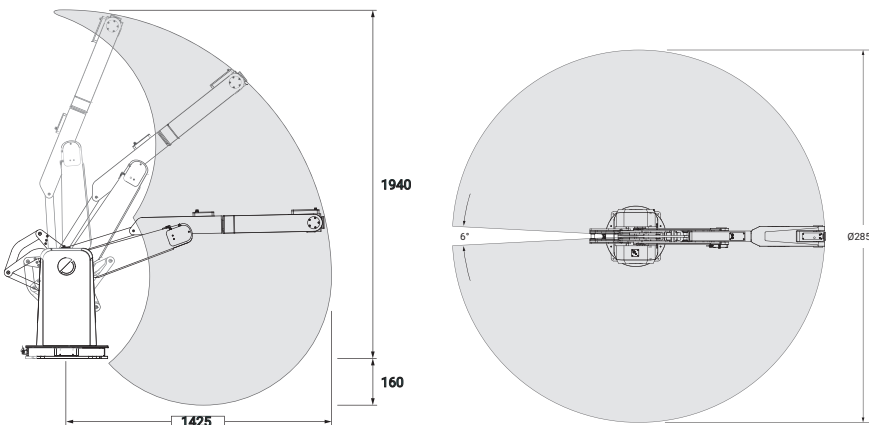

## Drilling pattern

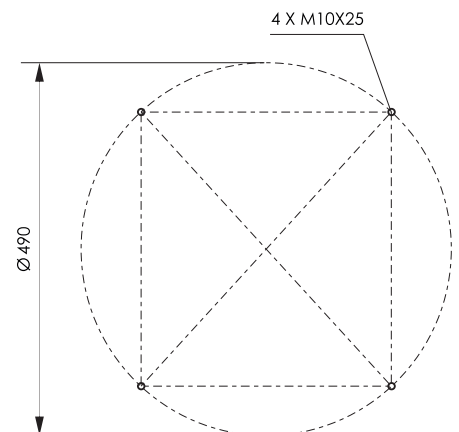



# User Interface

HorstFX allows to easily create industrial robot programs without having to write textual codes.

The intuitive graphic interface with touch screen operating panel and for touch screens in general, but it also works on desktop for maximum flexibility.



## Horst 1400 includes

- Switch cabinet
- Robot control touch panel
- HorstFX software

## Control and interfaces horstCONTROL

Dimensions (H x B x T)	313 mm x 174 mm x 446 mm
I/O connections on switch cabinet	20 digital input (expandable to 28) 18 digital output (expandable to 30)
I/O connections on tool flange	M8 male, 4-pin, angled, A-coded
I/O power supply	24V/7A at control 24V/2.5A at tool flange
Communication	TCP/IP 100-Mbit/s Ethernet [Web-Interface via HTTP]
Safety-relevant interfaces	Emergency stop [input and output]; Safety stop [input and output] in accordance with DIN EN ISO 10218-1
Fieldbus	Modbus/TCP Optional: Profinet

## Upstream communication possibilities

Modbus TCP/IP via Ethernet port



TCP/IP Sockets via Ethernet port



## Mobile robot base (available upon request)

A versatile multi-purpose platform equipped with emergency stop button, mounts for cabinet and panel and lockable door.

The aluminium base has multiple drilling patterns.



## Tool connectivity

Each interface provides power and control signals for grippers and sensors.

- 2 digital inputs/outputs
- 24 VDC current

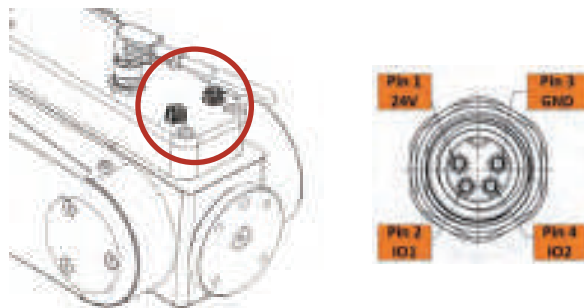

Electric grippers → No pneumatics → Easy maintenance

## Tool mounting Flange

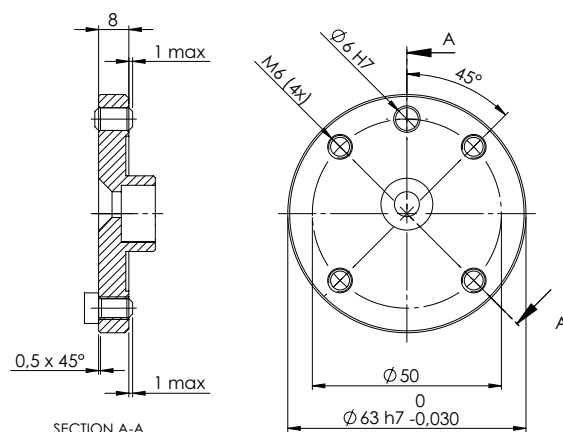





SCARA ROBOTS





# RX3-400

With its 400 mm horizontal reach and 3 kg payload, the RX3-400 SCARA robot is the ideal solution for small-scale assembly, pick and place, inspection and packaging applications requiring agility and high speed.



## Highlights

- 400 mm maximum range
- Up to 3 Kg Payload
- 5984 mm/s complex speed

## Main features

Number of axes	4
Maximum payload	3 kg
Nominal load	1 kg
Maximum range	400 mm
Protection	IP20
Weight	15 kg
Installation area	180x140 mm
Power supply	230 VAC, 50-60 Hz, 500 W

## Axis data

Axis	Repeatability	Stroke	Max Speed
1	± 0.02 mm	± 132°	600°/s
2	± 0.02 mm	± 141°	600°/s
3	± 0.015 mm	0~150 mm	1100 mm/s
4	± 0.01°	± 360°	2000°/s

Complex Speed  
5984 mm/s

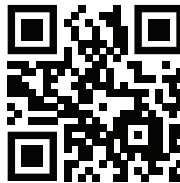

ACCESS HERE FURTHER TECHNICAL INFORMATION

## Operating Range

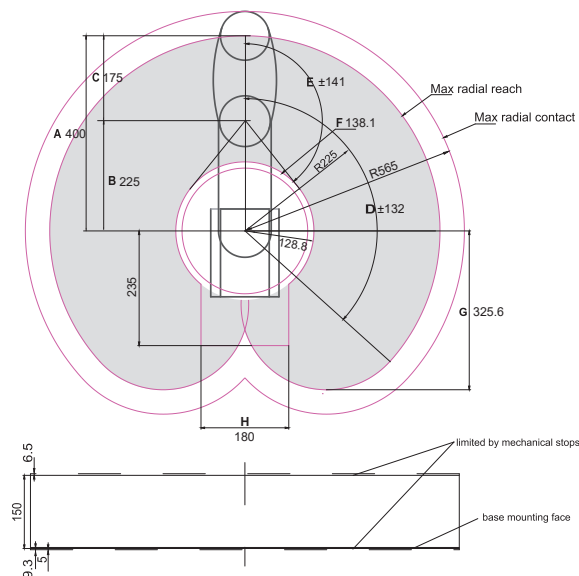

- A Length-Arm #1 & Arm#2 (mm)
- B Length-Arm #1 (mm)
- C Length-Arm #2 (mm)
- D Motion range-Joint #1 (°)
- E Motion range-Joint #2 (°)
- F Motion range (mm)
- G Motion range of backside (mm)
- H Motion range (mm)

## Drilling Pattern

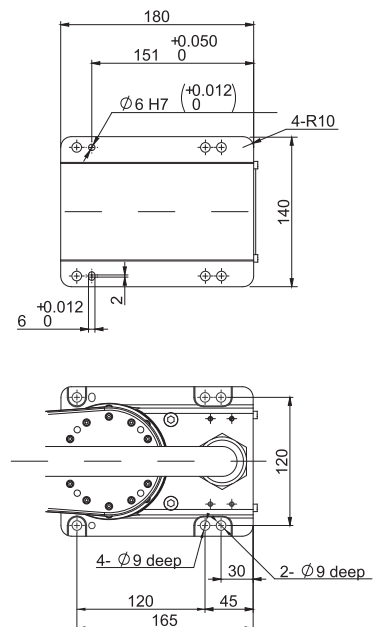

## Integration efficiency

Full integration with a selection of EtherCAT TRIO MOTION controllers, synchronizing multiple machine and robot axes within the native Trio software environment. The Controller has integrated robot path planning and can be programmed to control **more of the machine solution and integrate machine elements, including additional axes.**

Such a coordinated system simplifies the programming and maximizes performances.



### Upstream Communication Possibilities

Modbus TCP/IP Via Ethernet Port



TCP/IP Sockets Via Ethernet Port



EtherCAT®

TRIO  
MOTION TECHNOLOGY

Motion Perfect

### Connectivity

The RX3-400 SCARA gives the possibility to connect compressed air systems and electrical power via a 15 pin D-SUB connector for pneumatic and electrical end.

- |  |                         |
|--|-------------------------|
| <b>A</b> 15 pin D-SUB Electric Connector | <b>1-4</b> Power I/Os   |
| <b>B</b> 6 mm Pneumatic Connector        | <b>5-8</b> Encoder I/Os |
| <b>C</b> 6 mm Pneumatic Connector        |                         |
| <b>D</b> 4 mm Pneumatic Connector        |                         |

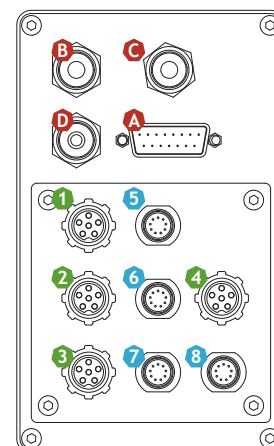

### Mechanical Dimension

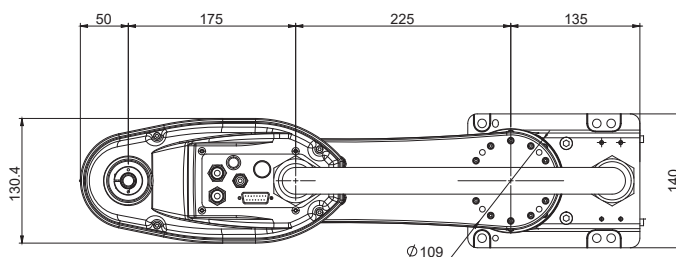
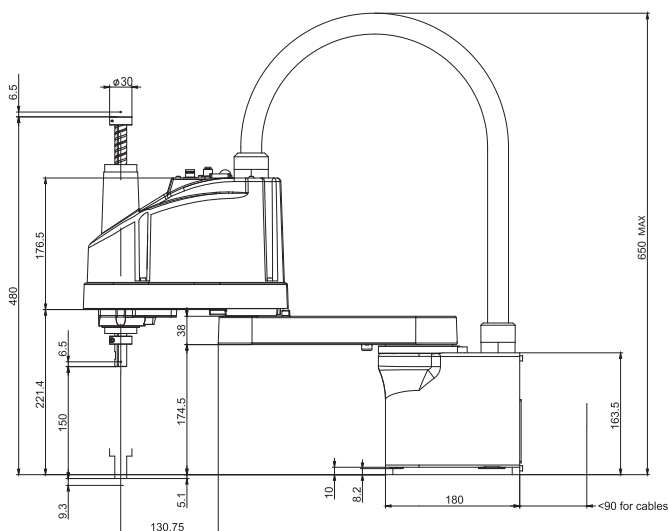

# RX6-500

The RX6-500 SCARA robot is a great choice for precise mechanical assembly, material handling, packaging, and screw driving industrial applications. Compact and light weighted, it has a payload capacity of up to 6 kg and 500 mm armreach.



## Highlights

- 500 mm maximum range
- Up to 6 Kg Payload
- 6094 mm/s complex speed

## Main features

Number of axes	4
Maximum payload	6 kg
Nominal load	2 kg
Maximum range	500 mm
Protection	IP20
Weight	18 kg
Installation area	195x169 mm
Power supply	230 VAC, 50-60 Hz, 800 W

## Axis data

Axis	Repeatability	Stroke	Max Speed
1	± 0.025 mm	± 132°	375°/s
2	± 0.025 mm	± 150°	588°/s
3	± 0.015 mm	0~200 mm	1100 mm/s
4	± 0.01°	± 360°	2000°/s

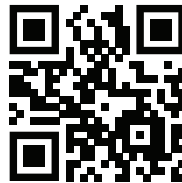

ACCESS HERE FURTHER TECHNICAL INFORMATION

## Operating Range

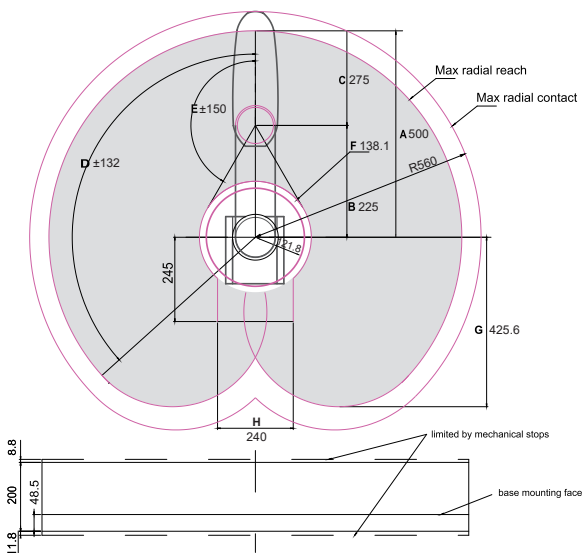

- A Length-Arm #1 & Arm#2 (mm)
- B Length-Arm #1 (mm)
- C Length-Arm #2 (mm)
- D Motion range-Joint #1 (°)
- E Motion range-Joint #2 (°)
- F Motion range (mm)
- G Motion range of backside (mm)
- H Motion range (mm)

## Drilling Pattern

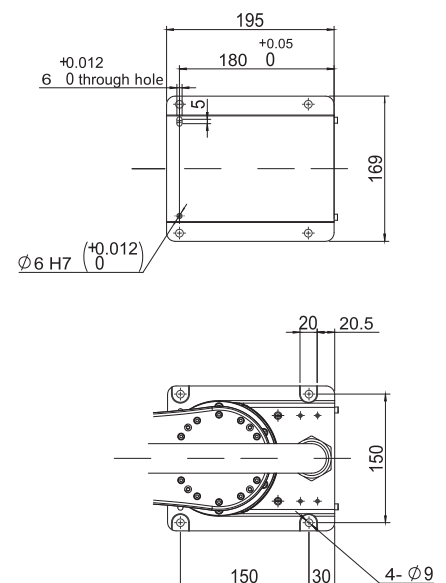

## Integration efficiency

Full integration with a selection of EtherCAT TRIO MOTION controllers, synchronizing multiple machine and robot axes within the native Trio software environment. The Controller has integrated robot path planning and can be programmed to control **more of the machine solution and integrate machine elements, including additional axes.**

Such a coordinated system simplifies the programming and maximizes performances.



### Upstream Communication Possibilities

Modbus TCP/IP Via Ethernet Port



TCP/IP Sockets Via Ethernet Port



EtherCAT

TRIO  
MOTION TECHNOLOGY

Motion Perfect

### Connectivity

The RX6-500 SCARA gives the possibility to connect compressed air systems and electrical power via a 15 pin D-SUB connector for pneumatic and electrical end.

- |  |                         |
|--|-------------------------|
| <b>A</b> 15 pin D-SUB Electric Connector | <b>1-4</b> Power I/Os   |
| <b>B</b> 6 mm Pneumatic Connector        | <b>5-8</b> Encoder I/Os |
| <b>C</b> 6 mm Pneumatic Connector        |                         |
| <b>D</b> 4 mm Pneumatic Connector        |                         |

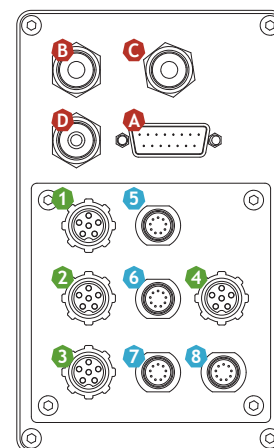

### Mechanical Dimension

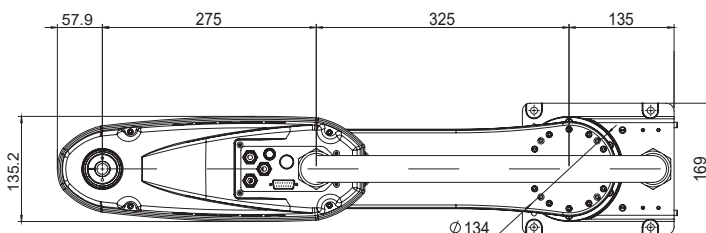
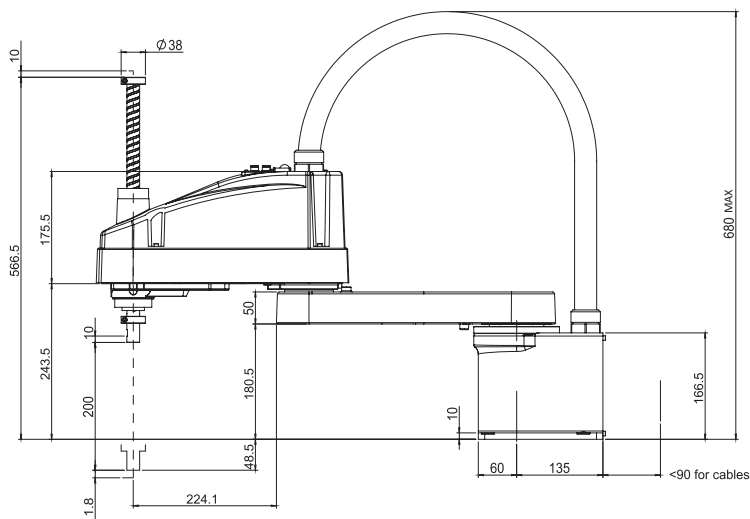

# RX6-600

The RX6-600 SCARA robot features a maximum operating range of 600 mm and up to 6 kg payload. Sitting in a small footprint, it offers high performance and reliability where precision and speed are required.



## Highlights

- 600 mm maximum range
- Up to 6 Kg Payload
- 7403 mm/s complex speed

## Main features

Number of axes	4
Maximum payload	6 kg
Nominal load	2 kg
Maximum range	600 mm
Protection	IP20
Weight	18 kg
Installation area	195x169 mm
Power supply	230 VAC, 50-60 Hz, 800 W

## Axis data

Axis	Repeatability	Stroke	Max Speed
1	± 0.025 mm	± 132°	375°/s
2	± 0.025 mm	± 150°	588°/s
3	± 0.015 mm	0~200 mm	1100 mm/s
4	± 0.01°	± 360°	2000°/s

Complex Speed  
7403 mm/s

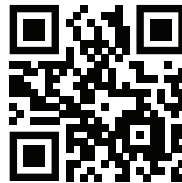

ACCESS HERE FURTHER  
TECHNICAL INFORMATION

## Operating Range

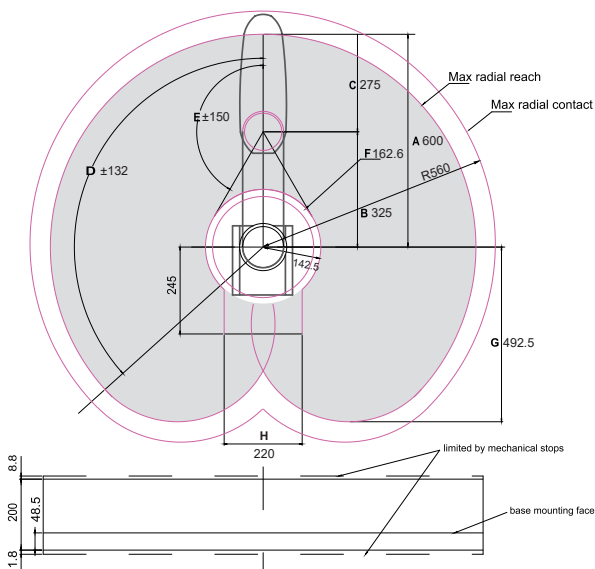

- A Length-Arm #1 & Arm#2 (mm)
- B Length-Arm #1 (mm)
- C Length-Arm #2 (mm)
- D Motion range-Joint #1 (°)
- E Motion range-Joint #2 (°)
- F Motion range (mm)
- G Motion range of backside (mm)
- H Motion range (mm)

## Drilling Pattern

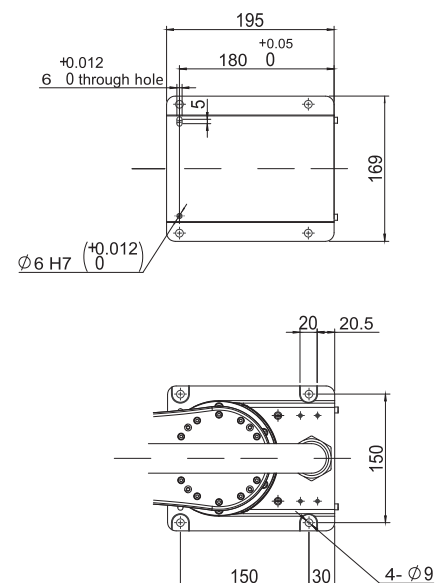



## Integration efficiency

Full integration with a selection of EtherCAT TRIO MOTION controllers, synchronizing multiple machine and robot axes within the native Trio software environment. The Controller has integrated robot path planning and can be programmed to control **more of the machine solution and integrate machine elements, including additional axes.**

Such a coordinated system simplifies the programming and maximizes performances.



### Upstream Communication Possibilities

Modbus TCP/IP Via Ethernet Port



TCP/IP Sockets Via Ethernet Port



EtherCAT®

TRIO  
MOTION TECHNOLOGY

Motion Perfect

### Connectivity

The RX6-600 SCARA gives the possibility to connect compressed air systems and electrical power via a 15 pin D-SUB connector for pneumatic and electrical end.

- |  |                         |
|--|-------------------------|
| <b>A</b> 15 pin D-SUB Electric Connector | <b>1-4</b> Power I/Os   |
| <b>B</b> 6 mm Pneumatic Connector        | <b>5-8</b> Encoder I/Os |
| <b>C</b> 6 mm Pneumatic Connector        |                         |
| <b>D</b> 4 mm Pneumatic Connector        |                         |

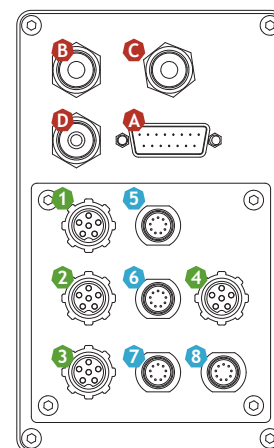

### Mechanical Dimension

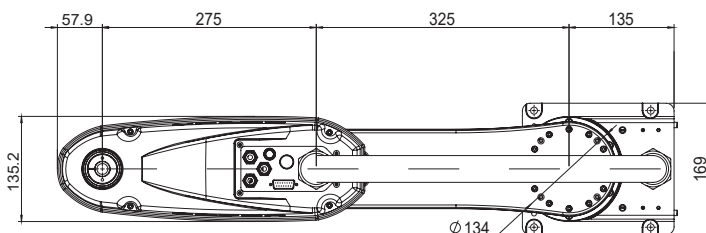
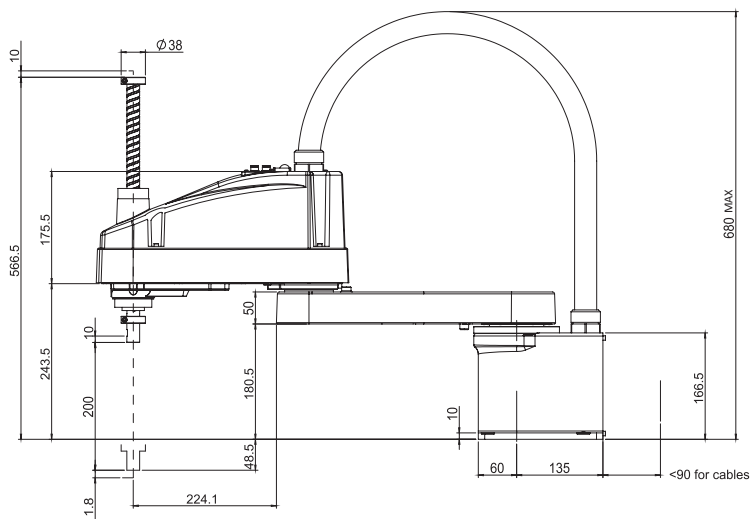

# RX6-700

RX6-700 is a robust high-cycle SCARA robot with arm length 700mm and 6kg maximum payload. It is perfect for applications requiring high speed and a wider operating area.



## Highlights

- 700 mm maximum range
- Up to 6 Kg Payload
- 7403 mm/s complex speed

## Main features

Number of axes	4
Maximum payload	6 kg
Nominal load	2 kg
Maximum range	700 mm
Protection	IP20
Weight	19 kg
Installation area	195x169 mm
Power supply	230 VAC, 50-60 Hz, 800 W

## Axis data

Axis	Repeatability	Stroke	Max Speed
1	± 0.025 mm	± 132°	375°/s
2	± 0.025 mm	± 150°	588°/s
3	± 0.015 mm	0~200 mm	1100 mm/s
4	± 0.01°	± 360°	2000°/s

Complex Speed  
7403 mm/s

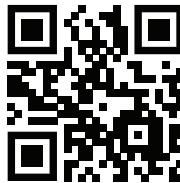

ACCESS HERE FURTHER TECHNICAL INFORMATION

## Operating Range

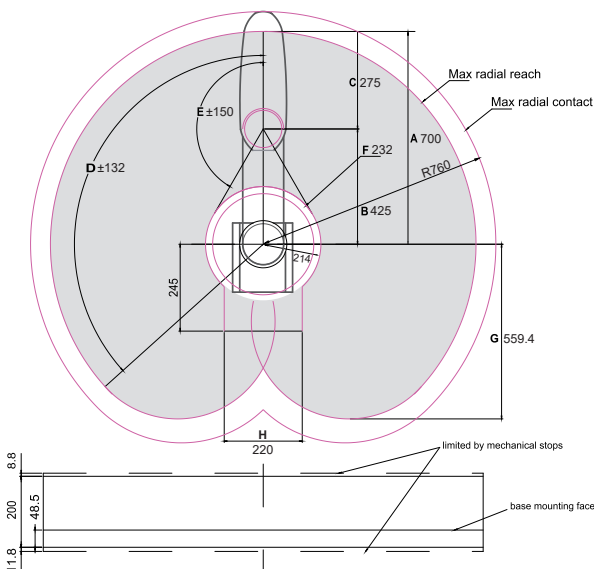

- A Length-Arm #1 & Arm#2 (mm)
- B Length-Arm #1 (mm)
- C Length-Arm #2 (mm)
- D Motion range-Joint #1 (°)
- E Motion range-Joint #2 (°)
- F Motion range (mm)
- G Motion range of backside (mm)
- H Motion range (mm)

## Drilling Pattern

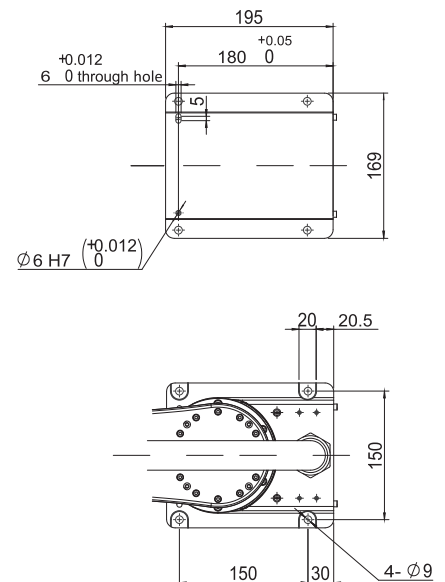

## Integration efficiency

Full integration with a selection of EtherCAT TRIO MOTION controllers, synchronizing multiple machine and robot axes within the native Trio software environment. The Controller has integrated robot path planning and can be programmed to control **more of the machine solution and integrate machine elements, including additional axes.**

Such a coordinated system simplifies the programming and maximizes performances.



### Upstream Communication Possibilities

Modbus TCP/IP Via Ethernet Port



TCP/IP Sockets Via Ethernet Port



EtherCAT®

TRIO  
MOTION TECHNOLOGY

Motion Perfect

### Connectivity

The RX6-700 SCARA gives the possibility to connect compressed air systems and electrical power via a 15 pin D-SUB connector for pneumatic and electrical end.

- |  |                         |
|--|-------------------------|
| <b>A</b> 15 pin D-SUB Electric Connector | <b>1-4</b> Power I/Os   |
| <b>B</b> 6 mm Pneumatic Connector        | <b>5-8</b> Encoder I/Os |
| <b>C</b> 6 mm Pneumatic Connector        |                         |
| <b>D</b> 4 mm Pneumatic Connector        |                         |

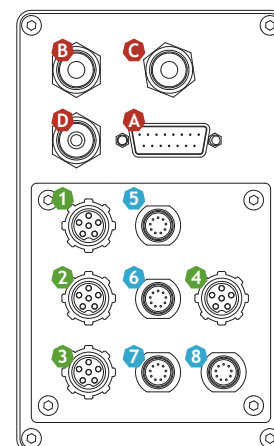

### Mechanical Dimension

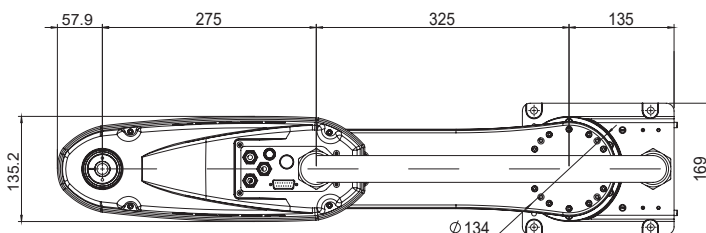
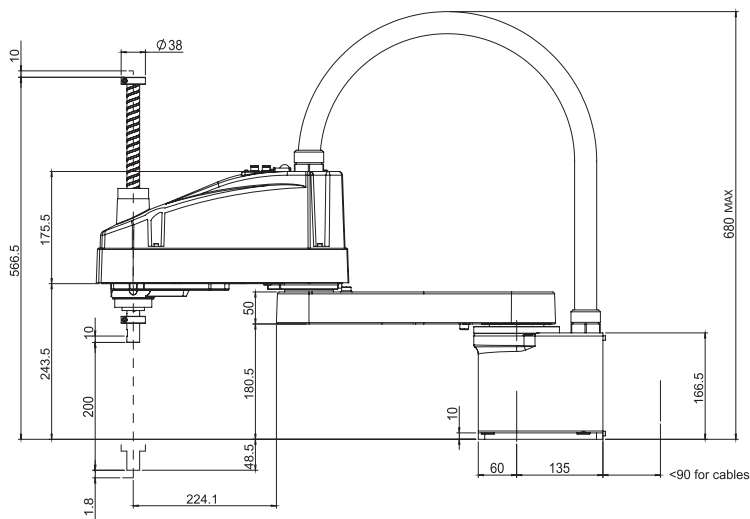



**R.T.A.Robotics - Headquarters**

Via E. Mattei 15, Fraz. Divisa - 27020 Marcignago (PV) ITALY  
T +39.0382.929.855 | F +39.0382.929.150

**R.T.A.Robotics - India office**

SCMC House, 16/6, 3rd Floor, Vishal Nagal Road, Pimple Nilakh  
Pune 411 027 - Maharashtra, INDIA  
T +91 942.250.744.5

[info@rta-robotics.it](mailto:info@rta-robotics.it) | [www.rta-robotics.it](http://www.rta-robotics.it)

