

EM 3F1H-04S0

Dimensions (Unit:mm)

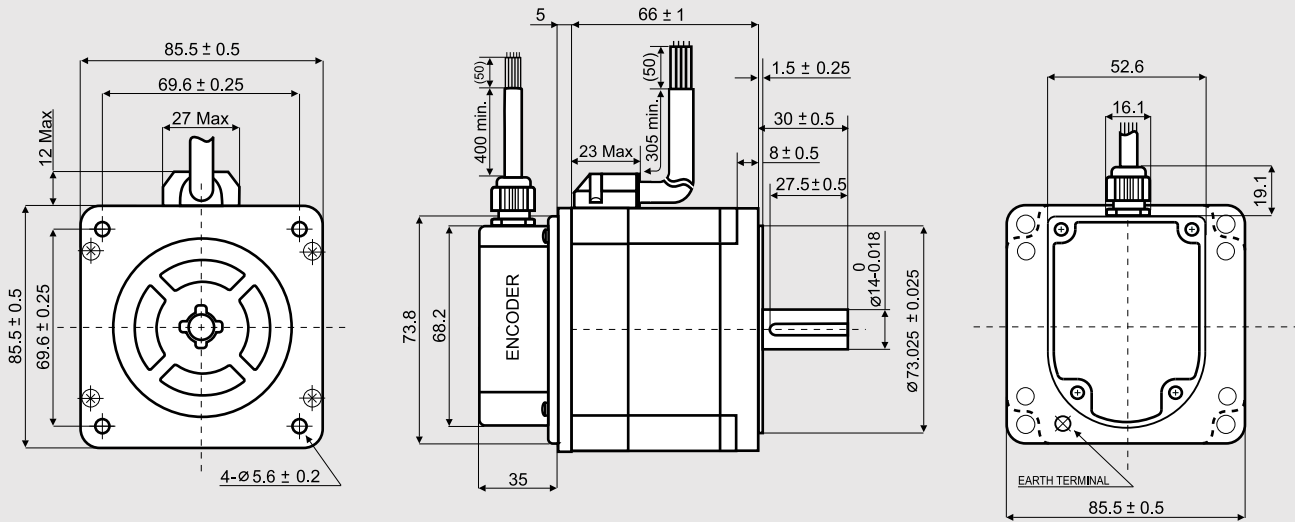

SANYO DENKI MOTOR FEATURES

MODEL	EM 3F1H-04S0
SANYO DENKI MOTOR CODE	SM 2861-5225
BASIC STEP ANGLE	1.8° ± 0.09°
BIPOLAR PARALLEL CURRENT	(Amp) 6.0
RESISTANCE	(Ohm) 0.29
INDUCTANCE	(mH) 1.7
BIPOLAR HOLDING TORQUE	(Ncm) 360
ROTOR INERTIA	(Kgm ² × 10 ⁻⁷) 1480
THEORETICAL ACCELERATION	(rad × sec. ⁻²) 24300
BACK E.M.F.	(V/Krpm) 60
MASS	(Kg) 1.8
INTERNATIONAL STANDARDS	UL, CSA
INSULATION VOLTAGE	(V) 250 VAC (350 VDC)
PROTECTION DEGREE - INSULATION CLASS	IP43 - F
LEADS CODE	V

TORQUE/SPEED CURVE

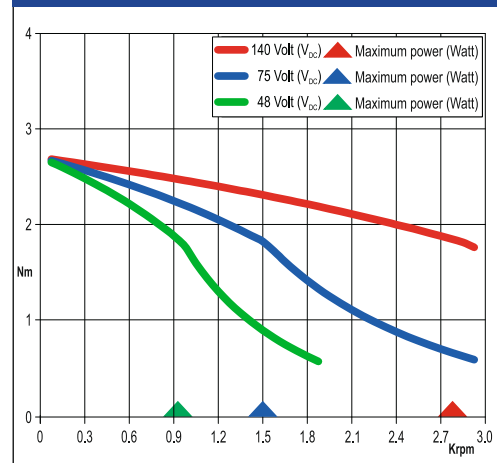

ENCODER FEATURES

POWER SUPPLY VOLTAGE	(Volt)	5 V _{dc} ± 5%
CURRENT CONSUMPTION	(mAmp)	35
HIGH LEVEL OUTPUT	(Volt)	3.4 (TIP) - 2.4 (MIN) (I _{max} =10 mA)
LOW LEVEL OUTPUT	(Volt)	0.2 (TIP) - 0.4 (MAX) (I _{max} =10 mA)
OUTPUT SIGNAL		Single Ended
RESOLUTION		400 cycles per revolution
MAXIMUM FREQUENCY	(KHz)	60

LEADS COLOR	ENCODER
BLUE	CHANNEL A
GREEN	CHANNEL B
BLACK	GND (0 V)
RED	+ DC (5 V)
SHIELD	

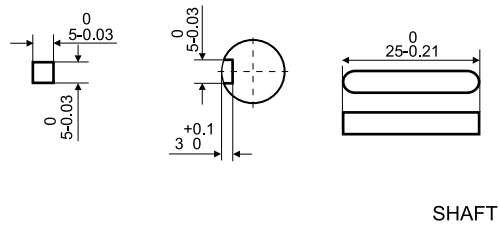
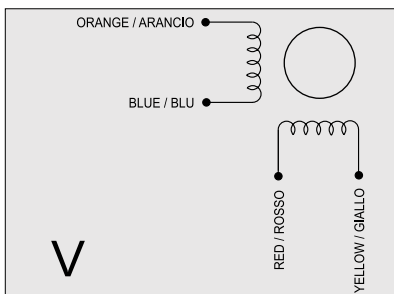

ENCODER OUTPUT WAVEFORM

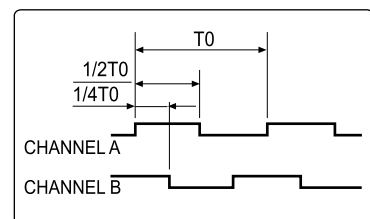

R.T.A. s.r.l.
Via E. Mattei - Fraz- Divisa
27020 Marcignago (PV) (Italy)
T +39.0382.929.855
F +39.0382.929.150
www.rta.it

R.T.A. Deutschland GmbH
Bublitzter Strasse 34, 40599
Duesseldorf (Germany)
T +49.211.749.668.60
F +49.211.749.668.66
www.rta-deutschland.de

R.T.A. IBERICA
C/Generalitat 22, Local 1
08850 Gava - Barcelona (Spain)
T +34 936.388.805
F +34 936.334.595
www.rta-iberica.es

R.T.A. INDIA Pvt
Teerth Business Center 3rd Floor, Unit No. 7,
Block EL-15, MIDC Bhosari Pimpri-Chinchwd,
Pune 411026 (India)
Tel. +91 9422507445
www.rta-india.in